



ENGINEERING SPECIFICATION

Technical requirements and design for the RDK (Rapid Development Kit) Board.
Model No: UMS-S001MD-050

MICROTIPS TECHNOLOGY USA
3504 Lake Lynda Dr, Suite 110,
Orlando, Florida, 32817,
TEL: 407-273-0204, FAX: 407-273-0771

+Document Approval:

Date Approved

Originator: Isis Pagan	10/17/2023
Nadim Rahman- Chief Technology Officer	approved

Revision History

Revision	Date Released	Description of Change
0	10/17/2023	Original Release

1 Table of Contents

2	Introduction for the RDK Kit	2
3	General Description for LCD + RDK Board	3
4	Interface Description for the RDK Board	4
4.1	Connector 10 (CN10) Pin Definition	5
4.2	Connector 9 (CN9) Pin Definition	7
4.3	DC Power Connector Pin Definition	9
4.4	Connector 5 (CN5) Pin Definition	10
5	Absolute Maximum Ratings for the RDK Board	11
6	Electrical Characteristics for the RDK Board	12
6.1	DC Characteristics	12
7	UART Communication Protocol for the RDK Board	13
7.1	Command Format	13
7.2	Data Payload Format	13
8	Mechanical Drawing (LCD + RDK Board)	14
8.1	Mechanical Drawing for UMS-S001MD-050	14
9	Mechanical Drawing with Extension Board – Optional	15
9.1	Mechanical Drawing for UMS-S001MD-050 with Wi-Fi Extension Board	15

2 Introduction for the RDK Kit

You are going to receive a box with the following components:



- LCD Display with RDK (Rapid Development Kit) Board
- Power Cables
- I/O Connectors

Our RDK comes with HMI software filled with Widgets and simulations capabilities so that you can easily design your user interface on the LCD Panel (**Figure 1**).

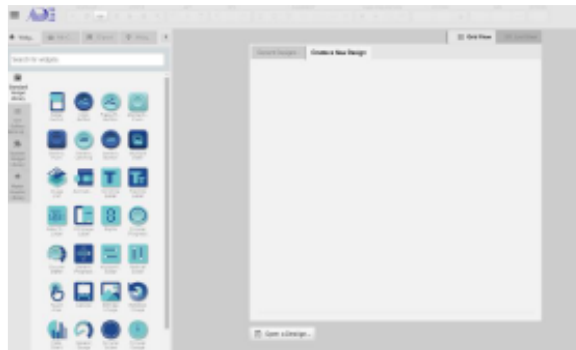

Figure 1

- This HMI software is called the ADE (Acorn Development Environment) and you can download it from here – <https://iot-hmi.com/ADE-Install>
- For reference manual and other educational materials including videos for the ADE, please visit - <https://manual.iot-hmi.com/en/3.4.1/>
- For educational videos, please access:
<https://www.youtube.com/@immenseoaktechnologies7277>
- If you have any questions, please contact Microtips Technology:
mtusainfo@microtipsusa.com

3 General Description for LCD + RDK Board

Ubique Panel product line provides total solutions for HMI. These solutions include ADE (Acorn Development Environment), control board and LCM. This datasheet is intended to describe the hardware part of the solutions. This document covers the following product:

Table 1. Ubique Panel Product Line

Part Number	Resolution	Panel Size	Touch Type
UMS-S001MD-050	800x480	5.0"	CTP

Note: CTP = Capacitive Touch Panel

The product must work with ADE to perform the HMI tasks designed in ADE. ADE is the ONLY HMI development tool you ever need going from design to deployment. It offers the following advantages:

- Free download HMI development platform
- Easy-to-Learn and Easy-to-Use development environment
- No-Code/Low-Code HMI development for faster time-to-market
- No compiler, driver, loader or any 3-party tool is required

4 Interface Description for the RDK Board

Figure 1. Control Board Outline

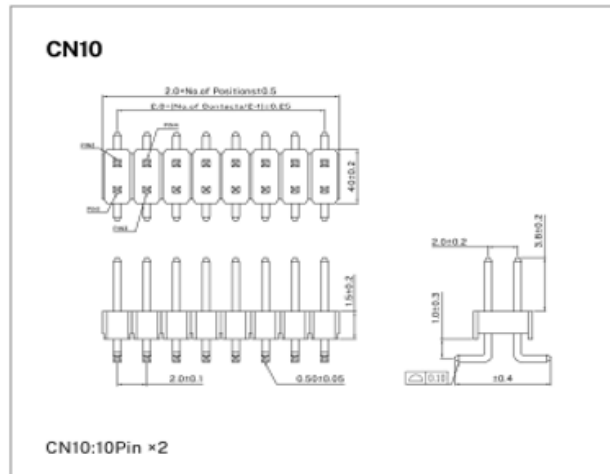
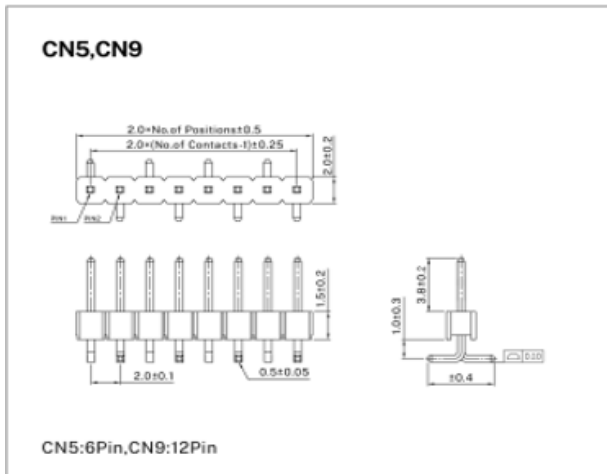
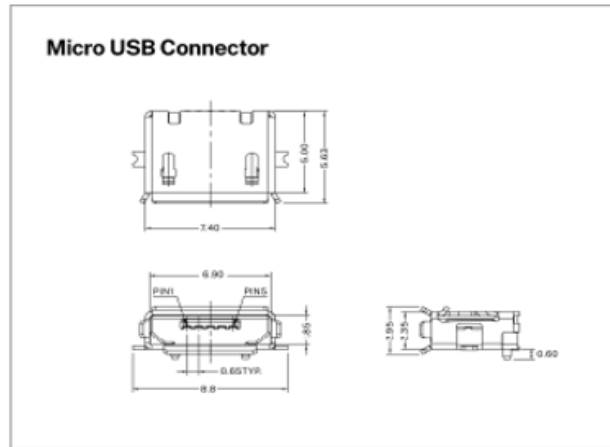
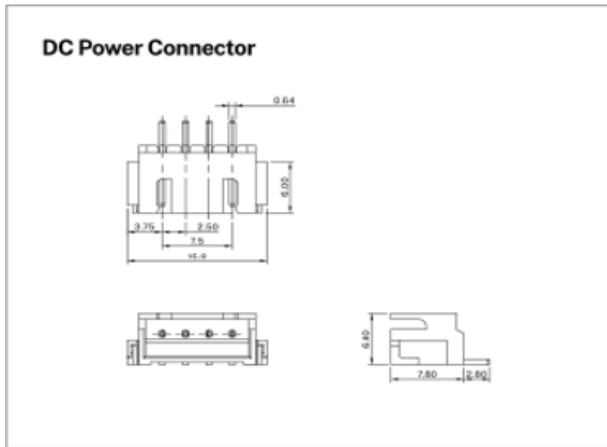
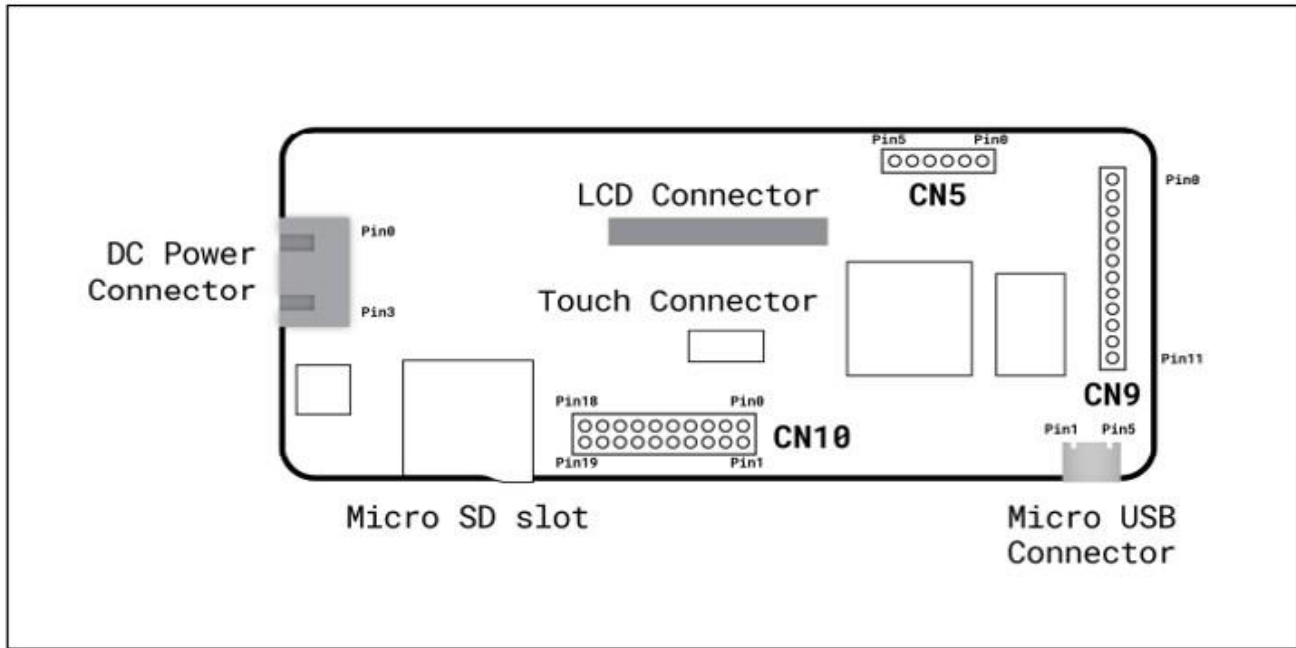

4.1 Connector 10 (CN10) Pin Definition

Figure 2. CN10 Pin Definition

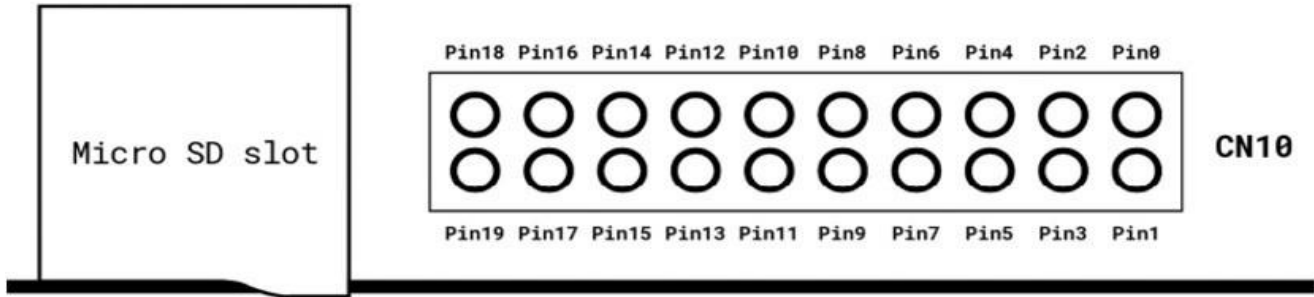

Table 2. CN10 Pin Definition

Pin Number	Name	I/O	Description
0	DC5V	P	DC 5V output.
1	GND	P	Supply Ground.
2	DC3.3V	P	DC 3.3V output.
3	GPIO1	I/O	General Purpose Input/Output, 3.3V Level - 5V Tolerant.
4	Reserved	N/A	Reserved.
5	GPIO2	I/O	General Purpose Input/Output, 3.3V Level - 5V Tolerant.
6	PWM4	I/O	This pin offers two different functions: GPIO and PWM. Users can select which function to be assigned to this pin inside ADE. For PWM, this pin generates digital pulses based on the parameters including frequency and duration set in the ADE.
7	GPIO3	I/O	General Purpose Input/Output, 3.3V Level - 5V Tolerant.
8	PWM5	I/O	This pin shares the same functionality as that of PWM4. Please refer to PWM4 description for details.
9	GPIO4	I/O	General Purpose Input/Output, 3.3V Level - 5V Tolerant.
10	PWM6	I/O	This pin shares the same functionality as that of PWM4. Please refer to PWM4 description for details.
11	GPIO5	I/O	General Purpose Input/Output, 3.3V Level - 5V Tolerant.
12	GND	P	Supply Ground.
13			

Pin Number	Name	I/O	Description
14	ADC0	I/O	General Purpose I/O pin with Analog Capability. This pin has a range of 0-3.3V when used as an Analog Input, and is 3.3V tolerant only.
15	ADC1	I/O	General Purpose I/O pin with Analog Capability. This pin has a range of 0-3.3V when used as an Analog Input, and is 3.3V tolerant only.
16	ADC2	I/O	General Purpose I/O pin with Analog Capability. This pin has a range of 0-3.3V when used as an Analog Input, and is 3.3V tolerant only.
17	ADC3	I/O	General Purpose I/O pin with Analog Capability. This pin has a range of 0-3.3V when used as an Analog Input, and is 3.3V tolerant only.
18	ADC4	I/O	General Purpose I/O pin with Analog Capability. This pin has a range of 0-3.3V when used as an Analog Input, and is 3.3V tolerant only.
19	ADC5	I/O	General Purpose I/O pin with Analog Capability. This pin has a range of 0-3.3V when used as an Analog Input, and is 3.3V tolerant only.

Note: I = Input, O = Output, P = Power

4.2 Connector 9 (CN9) Pin Definition

Figure 3. CN9 Pin Definition

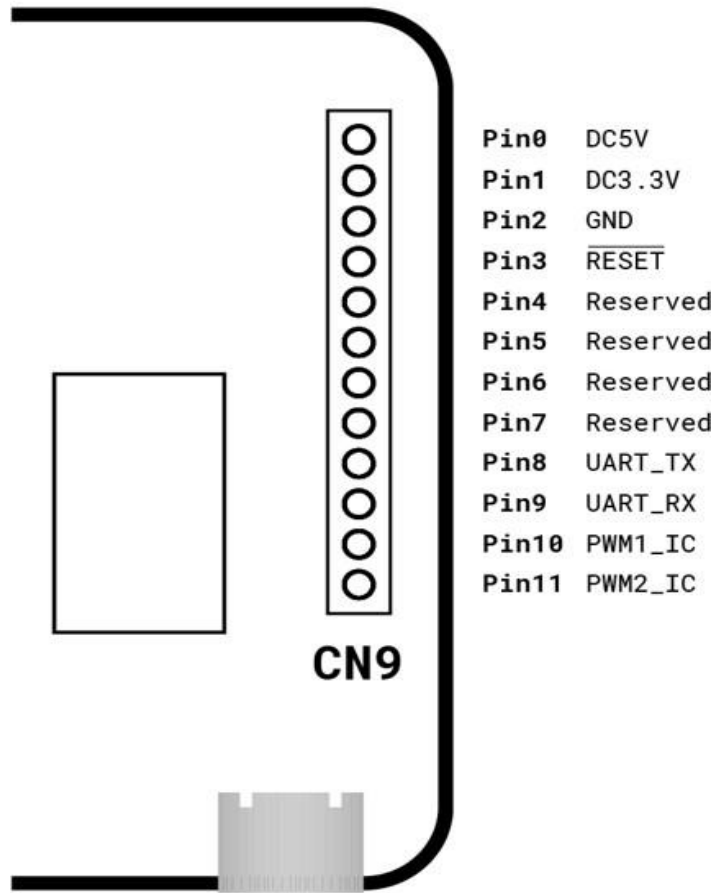

Table 3. CN9 Pin Definition

Pin Number	Name	I/O	Description
0	DC5V	P	DC 5V output.
1	DC3.3V	P	DC 3.3V output.
2	GND	P	Supply Ground.
3	$\overline{\text{RESET}}$	I	Reset signal. Active low.
4	Reserved	N/A	Reserved.
5	Reserved	N/A	Reserved.
6	Reserved	N/A	Reserved.
7	Reserved	N/A	Reserved.

Pin Number	Name	I/O	Description
8	UART_TX	I/O	<p>TX for UART</p> <p>Asynchronous Serial Transmit pin, TTL level. Connect this pin to the Receive (Rx) signal of other serial devices. Used in conjunction with the UART_RX pin for communication with external MCU by UART Communication Protocol (The communication protocol is described in chapter UART Communication Protocol). This pin is tolerant up to 5.0V levels.</p>
9	UART_RX	I/O	<p>RX for UART</p> <p>Asynchronous Serial Receive pin, TTL level. Connect this pin to the Transmit (Tx) signal of other serial devices. Used in conjunction with the UART_TX pin for communication with external MCU by UART Communication Protocol (The communication protocol is described in chapter UART Communication Protocol). This pin is tolerant up to 5.0V levels.</p>
10	PWM1_IC	I/O	<p>This pin offers three different functions: GPIO, PWM and Input-capture. Users can select which function to be assigned to this pin inside ADE.</p> <p>For PWM, this pin generates digital pulses based on the parameters including frequency and duration set in the ADE.</p> <p>For the input-capture, the capture mode and the corresponding behavior are all set inside ADE.</p>
11	PWM2_IC	I/O	<p>This pin shares the same functionality as that of PWM1_IC. Please refer to PWM1_IC description for details.</p>

Note: I = Input, O = Output, P = Power

4.3 DC Power Connector Pin Definition

Figure 4. DC Power Connector Pin Definition

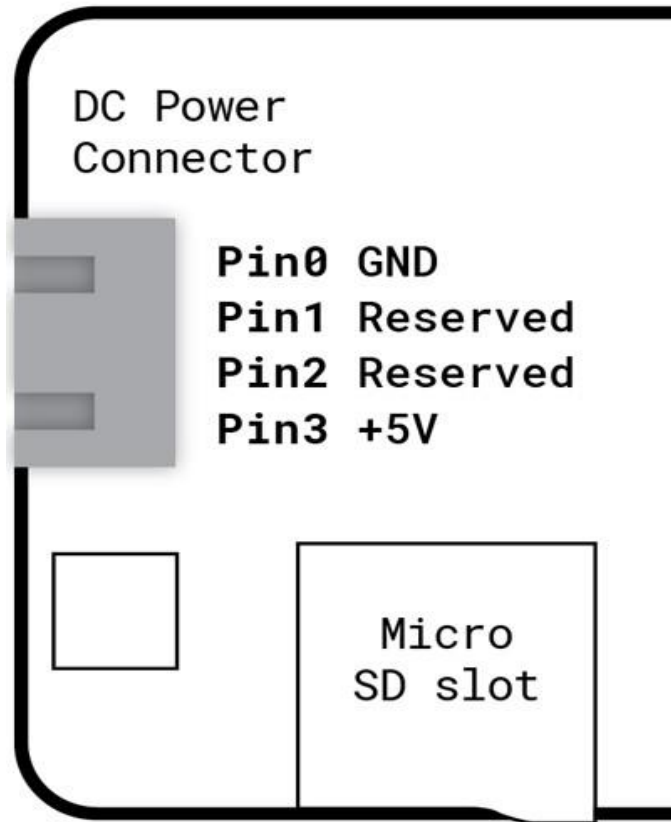

Table 4. DC Power Connector Pin Definition

Pin	Name	I/O	Description
0	GND	P	Supply Ground.
1	Reserved	N/A	Reserved.
2	Reserved	N/A	Reserved.
3	+5V	P	DC 5V input.

Note: I = Input, O = Output, P = Power

4.4 Connector 5 (CN5) Pin Definition

Figure 5. CN5 Pin Definition

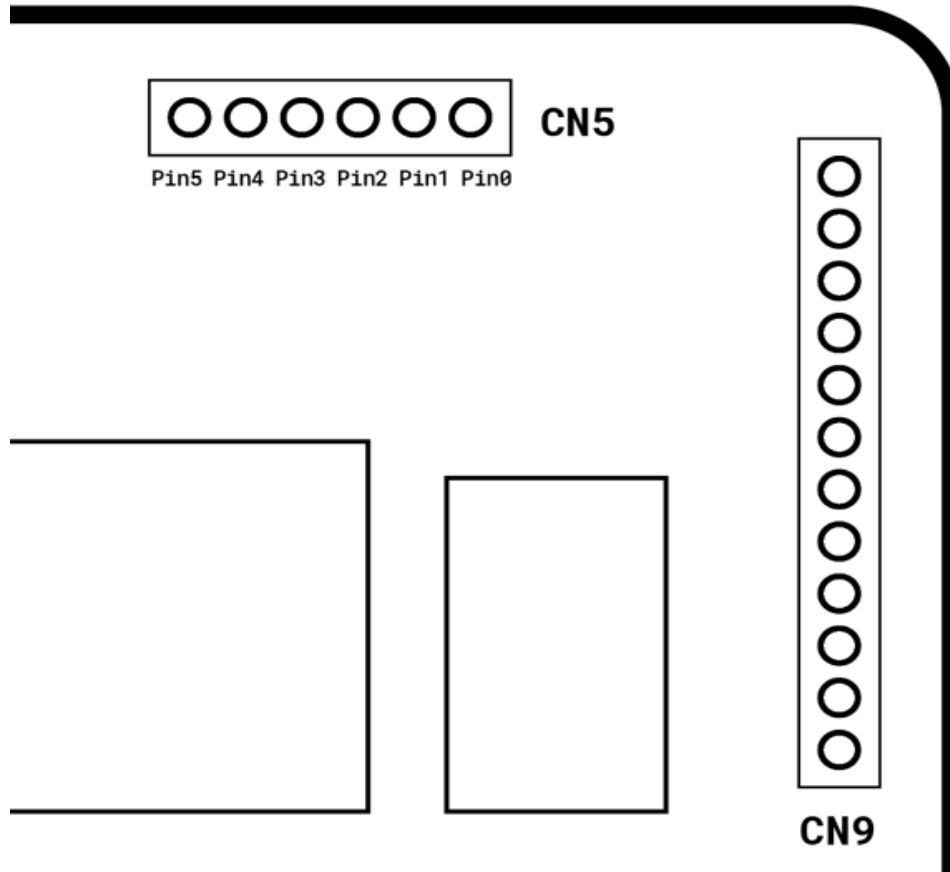

Table 5. CN5 Pin Definition

Pin	Name	I/O	Description
0	Reserved	N/A	Reserved.
1	Reserved	N/A	Reserved.
2	Reserved	N/A	Reserved.
3	Reserved	N/A	Reserved.
4	Reserved	N/A	Reserved.
5	Reserved	N/A	Reserved.

Note: I = Input, O = Output, P = Power

5 Absolute Maximum Ratings for the RDK Board

Table 6. Absolute Maximum Ratings

Item	Minimum	Maximum	Unit
Storage temperature	-30	+80	°C
Operating ambient temperature	-20	+70	°C
Input supply voltage with respect to GND	+4.75	+5.5	V
IO voltage with respect to GND	+3.3V (±10%)	+5.0	V

Note: IO Voltage is specified under the no-pull configuration.

6 Electrical Characteristics for the RDK Board

6.1 DC Characteristics

The following table is measured when the control board is driving a 5.0" LCM @800cd/m²

Table 7. DC Characteristic

Symbol	Item	Minimum	Typical	Maximum	Unit
V _{IN}	Input power voltage	4.75	5.0	5.5	V
V _{DD}	Internal working voltage	3.0	3.3	3.5	V
	Operating current @100% backlight	495	525	-	mA
	Operating current @50% backlight	355	375	-	mA
	Operating current with backlight turned off	250	265	-	mA
V _{IH}	I/O input high level	0.7V _{DD}	-	5.0	V
V _{IL}	I/O input low level	0	-	0.3V _{DD}	V
V _{OH}	I/O output high level	V _{DD} -0.4	-	V _{DD}	V
V _{OL}	I/O output low level	0	-	0.3V _{DD}	V

7 UART Communication Protocol for the RDK Board

7.1 Command Format

Table 8. Command Format

Command	Lead Byte	Type Byte	Register ID Low Byte	Register ID High Byte	Tailing Bytes
Set Register	0x11	0x00	0x00~0xFF	0x00~0xFF	Data Payload
Read Register	0x11	0x01	0x00~0xFF	0x00~0xFF	N/A

7.2 Data Payload Format

Table 9. Data Payload Format

Payload Type	ID Byte	Length Low Byte	Length High Byte	Tailing Bytes
Boolean	0x00	0x01	0x00	Data Bytes
String	0x01	0x01~0xFF	0x00~0xFF	Date Bytes
Integer	0x02	0x01/02/04/08	0x00	Data Bytes
Unsigned Integer	0x03	0x01/02/04/08	0x00	Data Bytes
Floating Point	0x04	0x04/08	0x00	Data Bytes

Note: Data bytes are of the Little-Endian format.

8 Mechanical Drawing (LCD + RDK Board)

8.1 Mechanical Drawing for UMS-S001MD-050

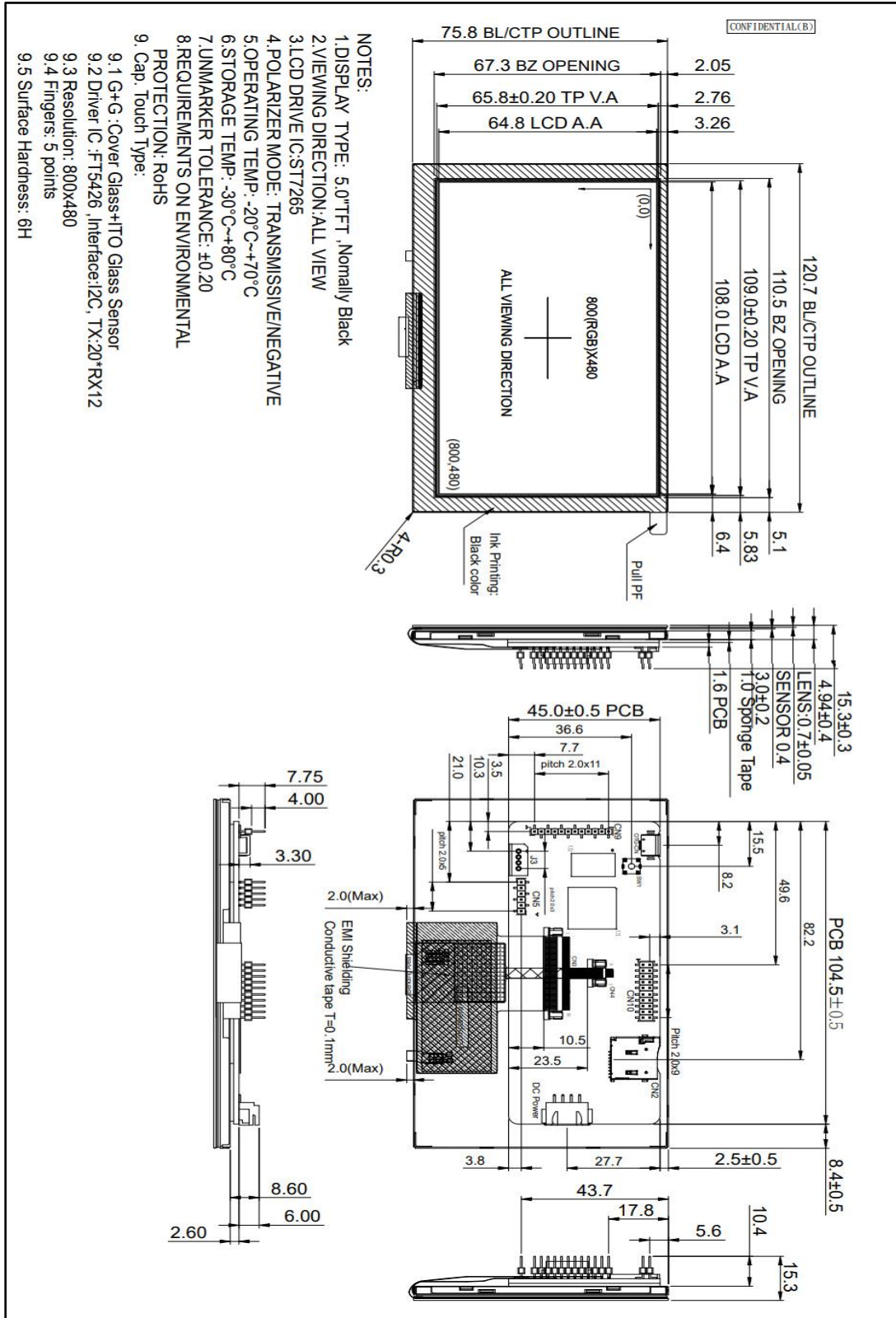
 for the full 5.0" LCD spec only, please download it from here <https://tinyurl.com/2s3hmez7>

9 Mechanical Drawing with Extension Board – Optional

9.1 Mechanical Drawing for UMS-S001MD-050 with Wi-Fi Extension Board

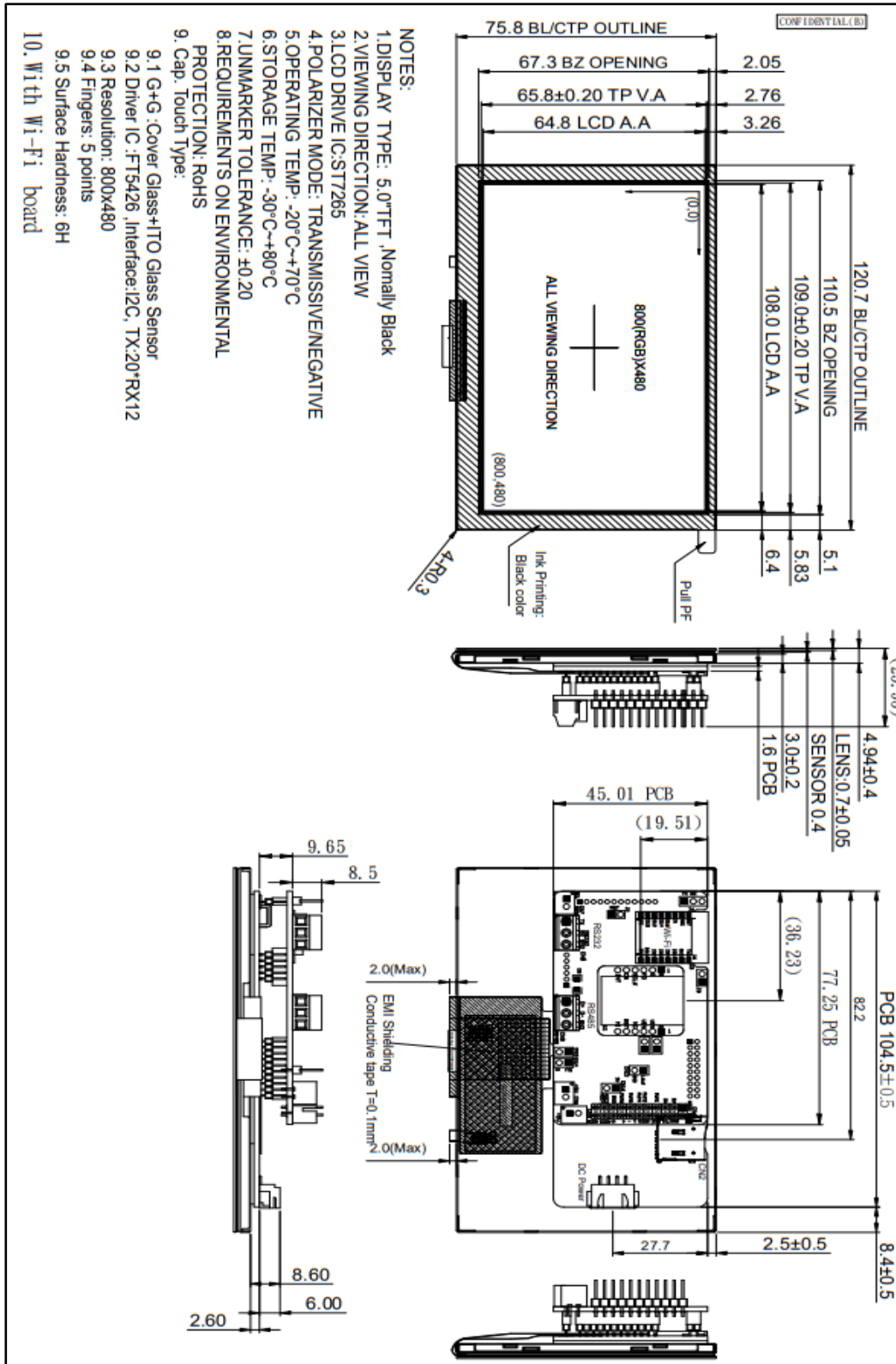

Note: This Extension Board will allow to connect the base of the RDK board as a hat to enable Wi-Fi functionality. Please contact mtusainfo@microtipsusa.com for more information.

MICROTIPS TECHNOLOGY USA

3504 Lake Lynda Dr, Suite 110, Orlando, Florida, 32817, TEL: 407-273-0204, FAX: 407-273-0771